



SANY

Quality Changes the World



VERSATILE SPECIALIST

POWER MEETS PRECISION.
COST-EFFECTIVENESS
MEETS FLEXIBILITY.

CONSTRUCTION MACHINERY



DEMOLITION EXCAVATORS **SY500HRD**

Engine
Isuzu 6WG1X
Rated power
298 kW / 2100 rpm
Max. reach height
28 m
Operating mass
64 000 kg

SANY

For challenging tasks, you need a first-class partner

Quality comes from experience. And from new ideas. This is why we combine these two crucial factors at SANY. This is because we are one of the world's leading producers, having sold more than **250 000** excavators in **10 years**. This means that you can always rely on sophisticated products that have been tried and tested in practice. An impressive **5–7%** of our annual turnover is dedicated to research and development. This is why we give you not only our word, but also our extraordinary **five-year warranty** as a guarantee of how powerful and robust our products are.

250 000
EXCAVATORS SOLD IN
10 YEARS

5–7%
TURNOVER FOR RESEARCH
AND DEVELOPMENT

FOUR-YEAR
WARRANTY*

Quality Changes the World

* Applicable in certain markets, please check with your local dealer.



SY500HRD

THE ALL-ROUND PERFORMER WHEN IT COMES TO DEMOLITION WORK

You know it well: Despite meticulous planning, you always have to expect the unexpected when carrying out demolition work. Therefore it is great when you have work equipment available that not only stands out thanks to its performance, but also thanks to its flexibility – such as the SANY SY500HRD. Designed for maximum productivity and endurance, it impresses with its robust design and its versatility. With its extra-long boom, it takes the demolition tools to a whole new level. And, thanks to the hydraulically extendible chassis, it achieves outstanding stability, even when things get really tough.

SY500HRD HARD FACTS

Swingspeed
7 rpm
Max. travel speed
1.4 km/h

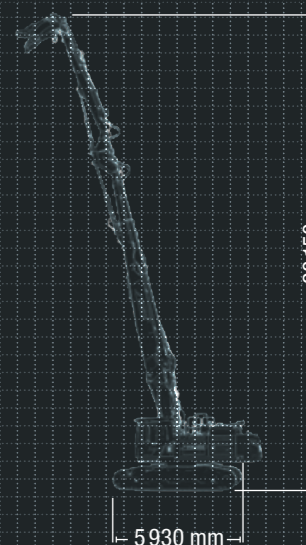

ECONOMY

SETS NEW STANDARDS FOR PRODUCTIVITY

Huge performance but with operating costs that are as low as possible. The SY500HRD knows how cost-efficiency works today. Its auto-idle function and the electronic fuel injection adjust the engine speed to the power required. This reduces the fuel consumption, engine wear and exhaust emissions. The long intervals for maintenance and service have a positive effect on the operating costs.

Achieve more with less fuel

You can rely on the water-cooled six-cylinder engine with common rail injection in every respect. It scores highly with exemplary values not only when it comes to reliability and performance, but also when it comes to consumption. Reduced fuel and AdBlue consumption reduces the ongoing operating costs on the one hand and, on the other hand, also reduces emissions. The two variable displacement axial piston pumps guarantee a maximum flow of 360 l twice per minute. In doing so, the power of the hydraulic pump is always automatically adjusted to the actual power that is required.



DIMENSIONS

Tall and stable – with its 28 m boom, the SY500HRD allows for precise demolition work, even on tall buildings and constructions.

USER EXPERIENCE

Work comfortably – using the tilting cab, the driver can always select the position with the best-possible view.

ECONOMY

Efficiency meets power – the intelligent control system automatically adapts the pump power to the available engine power.

QUALITY

For the toughest conditions – Precision welded seams, executed by highly-precise welding robots, ensure stability and power in the long term.

SAFETY

Totally safe – in addition to the extensively glazed driver's cab, the standard camera guarantees visibility on all sides with no blind spots.

COMPONENTS

A force for good – the tried-and-tested, large-scale Isuzu engine guarantees reliable performance even in the harshest of working conditions.

ECONOMY

Efficiency that pays dividends

The SANY SY500HRD has been designed for maximum productivity under continuous stress. Constructed especially for tough conditions during demolition work, it impresses thanks to its extraordinary durability and productivity. High level of operational safety and low operating costs, for example thanks to maximum fuel efficiency, mean that it is an economically well-considered investment when it comes to continuous use in quick and precise demolition work.

Absolute reliability – for peace of mind!

SANY's four-year warranty* gives you the assurance that you can fully count on your equipment.



* With participating partners

ECONOMY

Quick and easy maintenance

Regular maintenance and professional service are the be-all and end-all when it comes to maintaining machine's performance and functionality. On the SY500HRD, all serviceable components are therefore easily accessible. Suitably large maintenance compartments and an engine bonnet on the superstructure make maintenance and service quick and easy. This saves on operating costs and increases cost-effectiveness.



USER EXPERIENCE

MAXIMUM PRODUCTIVITY IN A COMFORTABLE ENVIRONMENT

Particular attention was paid to the driver's cab on the SY500HRD. In the cab, safety and ergonomics are perfectly interconnected and therefore offer the driver the best conditions for relaxed and fatigue-free work. The focus here is on the comfortable, air-suspension driver's seat with high backrest that provides lumbar support and the easily accessible controls. The joystick control allows for precise work in any situation and the large, easy-to-read display shows all of the key parameters clearly at a glance. The powerful heating and the automatic air-conditioning system guarantee the ideal climate. The cab, which can be tilted at an angle of up to 30°, also conveniently provides the driver with an optimum view of the relevant work area.



DIMENSIONS

Improved stability, increased transferable force

The SY500HRD has a wide, hydraulically telescopic chassis with an extremely stable and robust frame. The large footprint that is achieved in this way provides the basis for the driver to work safely and precisely, even on uneven ground. This also gives the SY500HRD the best

stability – meaning that the power is used in the best way possible. Perfect for providing maximum safety on the construction site thanks to the stability. A smart way to offer a lower track width for transport or for narrow areas.

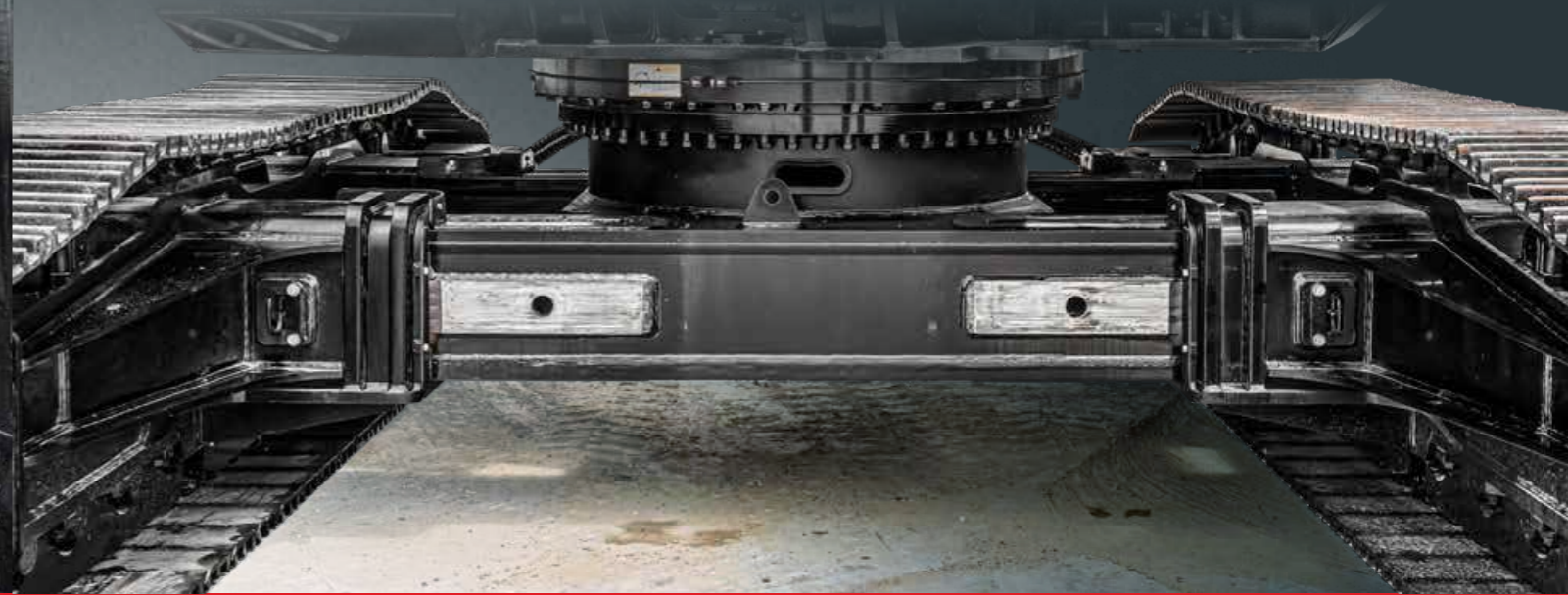

Our highlights – the added benefits SANY offers you:

- + Telescopic chassis for optimum stability
- + Tilting driver's cab for the best-possible view
- + High-reach with 28 m boom
- + Total safety package, including camera
- + Powerful, large-volume engine
- + Particularly robust, for example due to precise, robot-controlled weld seams

DIMENSIONS

For those who want to aim high

The SANY SY500HRD can really pitch in when it comes to demolition work. Even on challenging demolition sites, it sets standards with its extra-long 28 m boom. With this superior reach, it is also a good option in areas where other machines had to give up long ago. This considerably expands the possible applications and allows for faster, safer work, without the need for lengthy searches for compromise solutions. The particularly wide chassis allows the machine to cover an unusually wide work area while remaining fully stable.

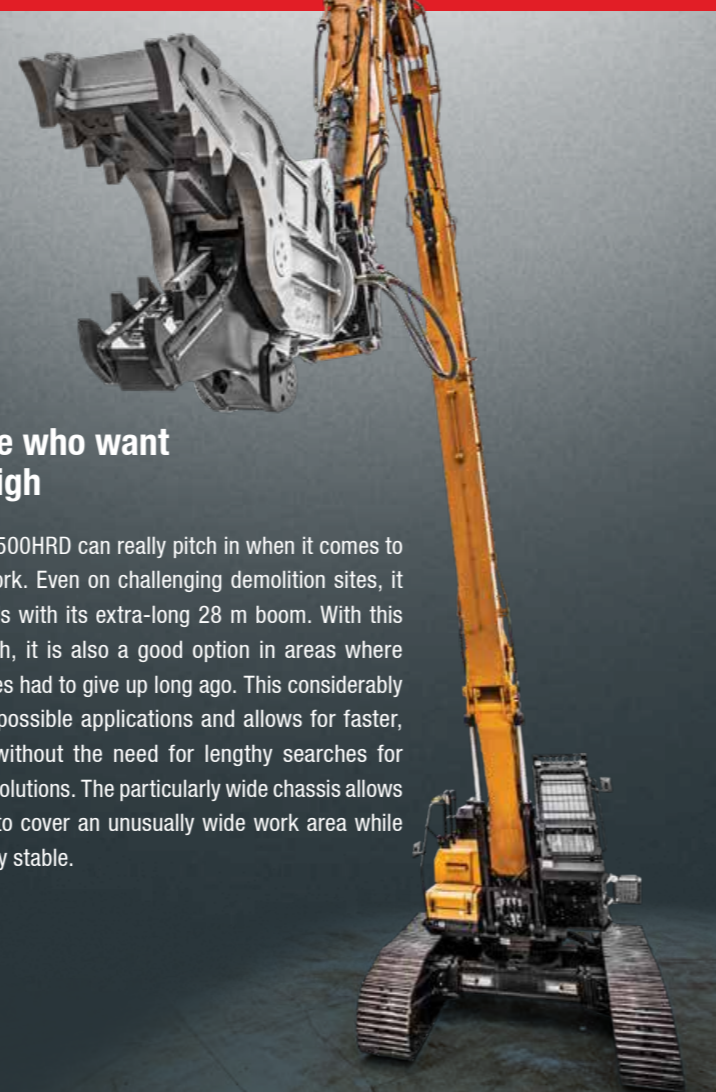

SAFETY

SAFETY WITHOUT COMPROMISES

Even on demolition sites, safety is the highest priority. The demolition cab on the SY500HRD is therefore extremely robust in accordance with the EU directive. The roof panel and windscreen, which are made from safety glass, are located behind protective grilles, which are part of the standard equipment. Numerous active and passive safety components, such as the automatic range limitation, ensure that both people and the machine are protected as much as possible.

SAFETY

People and machines – fully protected

The standard camera guarantees first-class visibility on all sides, which prevents blind spots and reliably protects people and the machine. Furthermore, the design is particularly robust. All of the cladding parts are exclusively manufactured from metal and are therefore ideally suited for the harsh conditions on the construction site.



ENGINE

Model	Isuzu 6WG1X
Exhaust emissions	Tier 3
Rated power	298 kW / 2 100 rpm
Max. torque	2 034 Nm / 1 400 rpm
Displacement	11 800 ccm
Batteries	2 × 12 V / 200 Ah

HYDRAULIC SYSTEM

Main pump	2 x variable displacement axial piston pumps with electrical control
Max. oilflow	2 × 360 l/min
Max. oilflow (AUX1)	720 l/min
Travel motor	Variable displacement axial piston engine
Swing motor	Axial piston engine

RELIEF VALVE SETTINGS

Implement circuit	343 bar
Power boost	373 bar
Swing circuit	269 bar
Travel circuit	343 bar
Pilot pressure	39 bar

SERVICE REFILL CAPACITIES

Fuel tank	680 l
Engine coolant	49.19 l
Engine oil	33 l
Drive (per side)	15 l
Hydraulic oil tank	480 l

PERFORMANCE

Swingspeed	7 rpm
Max. travel speed	1.4 km/h
Max. travel force	665 kN
Max. crusher weight	2 400 kg
Ground pressure	0.74 kg/cm ² (0.62 kg/cm ² *)
Gradeability	10°

UNDER AND UPPER STRUCTURE

Boom length	15 200 / 2 700 mm (7 782 mm *)
Arm length	8 500 mm (3 350 mm *)
Bottom rollers	12
Top rollers	2
Rotation device	Planetary gear driven by an axial piston engine, hydraulically triggered automatic parking brake

OPERATING MASS

SY500HRD - High Reach	64 000 kg
SY500HRD - Standard arm	54 000 kg
SY500HRD - w/o arm	41 000 kg

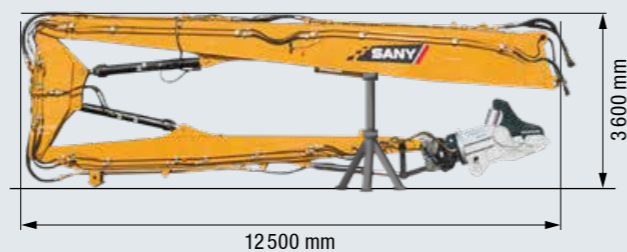
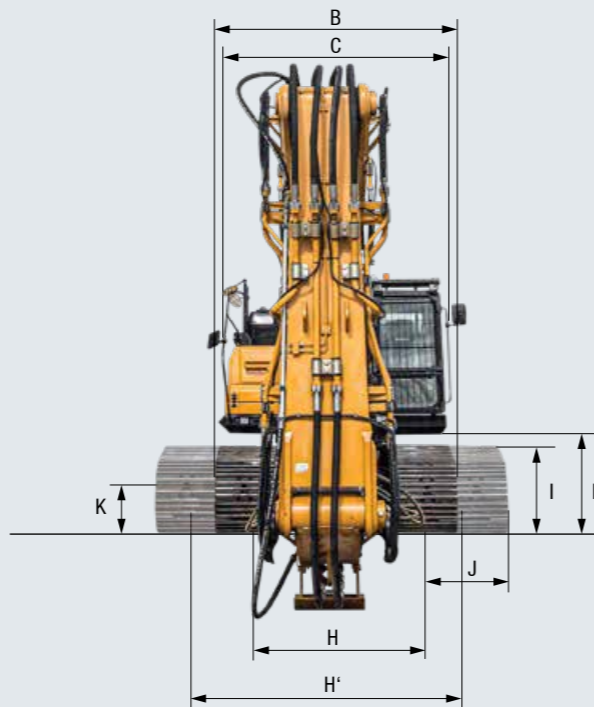

DIMENSIONS (TRANSPORT)

A	Transport length	19 850 mm
A'	Transport length	8 500 mm
A''	Transport length	13 200 mm
B	Transport width	3 340 mm
C	Upperstructure carriage	3 290 mm
D	Height over cabin/ROPS	3 476 mm
E	Height of Boom – transport	3 550 mm
E'	Height of Boom – transport	3 950 mm
F	Overall length of crawler	5 930 mm
G	Tail length	4 065 mm
H	Track gauge	2 400 mm
H'	Track gauge	3 500 mm
I	Track height	1 134 mm
J	Track pads width	800 mm
K	Min. ground clearance	451 mm
L	Counterweigh clearance	1 355 mm
M	Engine cover height	3 100 mm
N	Tail swing radius	4 065 mm
O	Center distance of tumbler	5 000 mm

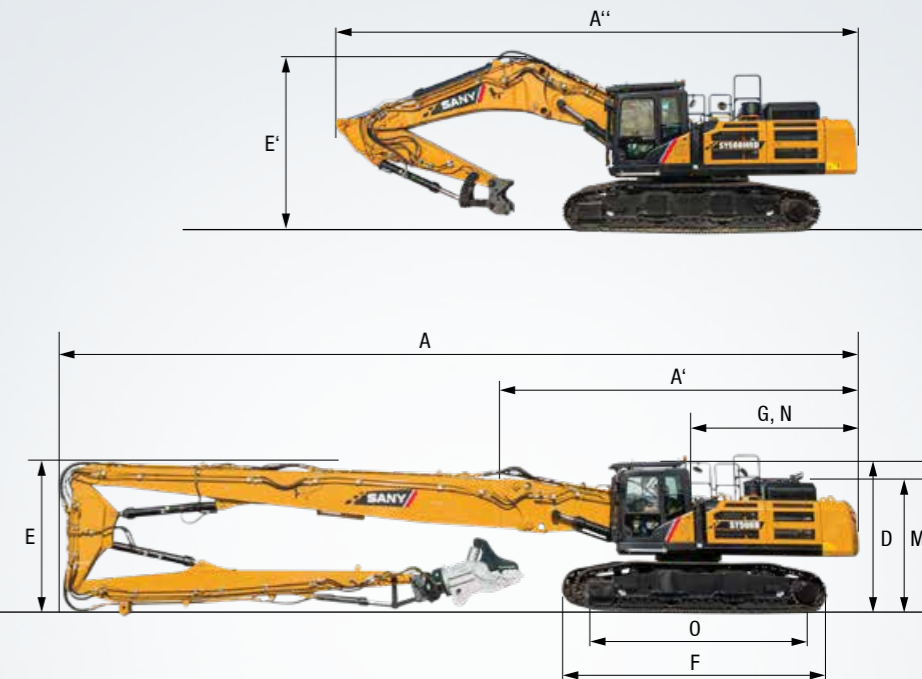

DEMOLITION EXCAVATOR WORK AREA WITH HIGH REACH

A	Max. reach	15 300 mm
B	Max. reach height	28 150 mm
C	Min. reach height	7 575 mm
D	Min. swing radius	5 470 mm

WORK AREA*

Max. digging reach	12 712 mm
Max. digging height	12 440 mm
Min. dumping height	5 354 mm
Overall height over arm by min. swing radius	10 331 mm
Min. swing radius	5 470 mm

* without illustration accordingly the standard version with boom

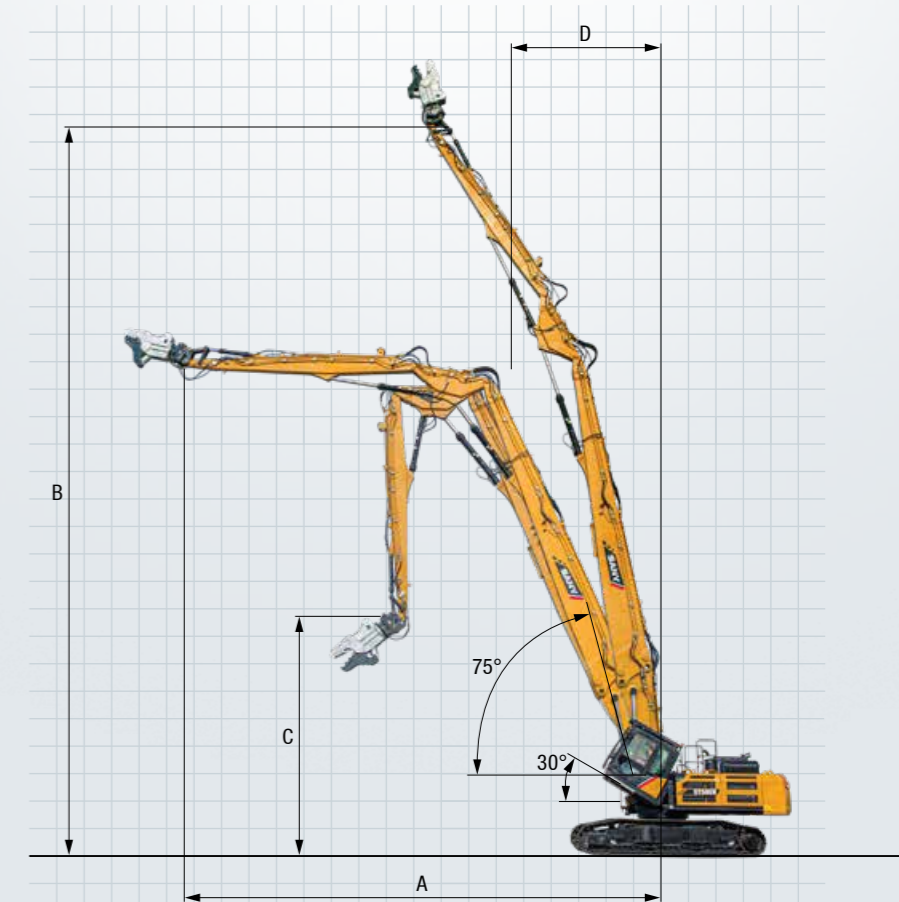
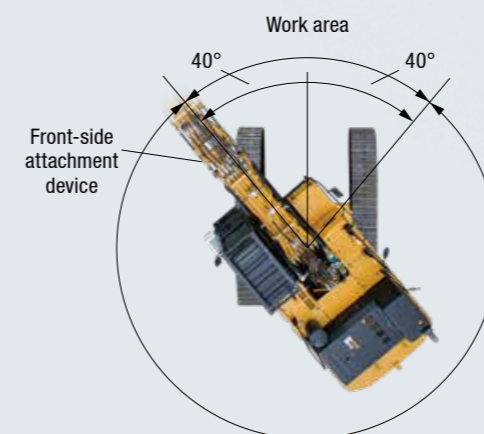

A true powerhouse with a flair for all challenges

Thanks to its extensive standard equipment, the SY500HRD is the perfect machine for working with special demands. Every task can be successfully undertaken with the SY500HRD, with its unique performance and comfortable workplace.



OPERATORS COMFORT / CABINE

- Heater ●
- Automatic air conditioning ●
- Radio and speaker ●
- Armrests (adjustable) ●
- Airsuspension seat ●
- Heated seat ●
- Wiper ●
- Sprayer f. wiper ●
- AUX 1 on Joystick ●
- Removable front-window ●
- Sky light openable ●
- Integrated cooling box ●

WORKING EQUIPMENT

- Boom and arm load holding valves with overload indicator ●
- Breaker&Shear line proportional via foot pedal incl. piping ●
- Middle arm via foot pedal ●
- Rotation line on joystick incl. piping ●
- Flow adjustment for attachments ●
- Incl. standard arm ●

UNDERCARRIAGE

- Steel tracks 800 ●
- Holes/loops for fixing ●

Standard equipment ● Special option ●

The standard and special options differ depending on the country in which the crawler excavator is delivered. If you have any questions, please contact your dealer directly.

WORKING LIGHTS

- Lights – front roof (LED) ●
- Lights – platform (LED) ●

ENGINE

- Auto idle ●
- Diesel filter ●
- DOC ●

HYDRAULIC SYSTEM

- Swing brake ●
- Piping for additional hydraulic function AUX 1 ●
- Hydr. Pre-pressure operating joysticks ●
- Mainfilter ●

SAFETY

- Battery master switch ●
- Travel Alarm ●
- Warning beacon ●
- Camera ●
- Handrails ●
- Lockable hoods ●
- Lockable fuel cap ●

A SERVICE YOU CAN RELY ON

In the event of a breakdown during your warranty period, Vertu will come to your site as soon as possible to get your machine back up and running. If the repair cannot be undertaken on-site or in good time, Vertu will arrange a similar replacement while your machine is repaired under warranty.

National Service Representative

Our national service network partnerships provide certainty that you are supported with service and parts, wherever you are located.

Parts and Inventory

As the dealer of SANY excavators, roading and construction equipment, Vertu holds a significant inventory of SANY genuine and aftermarket parts and attachments, both in New Zealand and Australia to keep you going. With direct relationships locally and internationally, we can source parts quickly and as a matter of priority.

Flexible, fast and always there for you

Paid assistance, tailored advice and a reliable supply of original parts all around Victoria. That is what we mean by premium service.

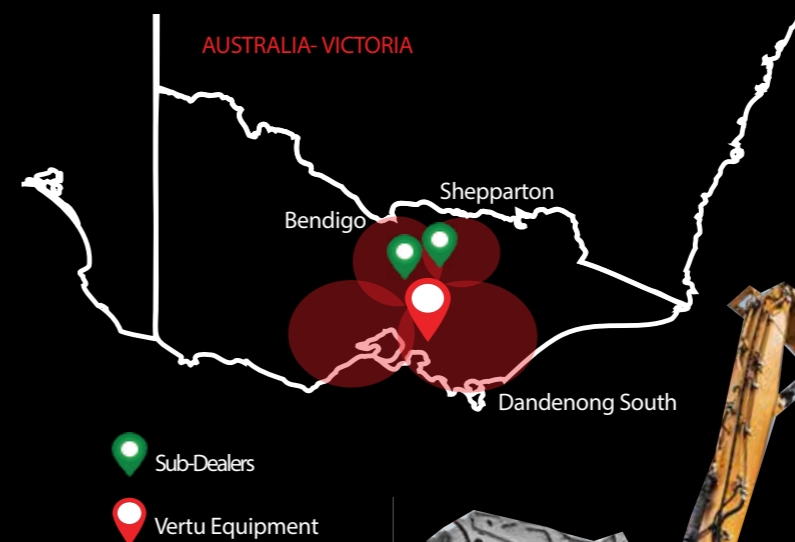

The added benefits SANY offers you:

- + Fast supply thanks to SANY Victoria location
- + More than 15,000 spare parts to make your machine highly reliable
- + Expert knowledge for optimal supply for your machine
- + Thanks to SANY's special training programme, our techs are always kept up-to-date so that they can face all technical challenges.

Parts supply – quick and reliable

By purchasing a SANY demolition excavator, you have invested in the future. Fast availability of spare parts is your guarantee of minimal downtimes and failure times.



Detailed information in black and white

Handbooks and documents are available for all SANY demolition excavators, and these can help you with operation, maintenance, servicing and repairs. These include operating and maintenance instructions and technical specifications.



HIGHLIGHTS **SY500HRD**

THE SPECIALIST THAT IS REDEFINING VERSATILITY



The SY500HRD impresses in every respect. Its high-quality, robust design and its powerful hydraulics make it the expert that you need when tackling demanding demolition work. It feels at home even under the toughest operating conditions, and demonstrates how important flexible work is for cost-effective operation.

FOR THE TOUGHEST CONDITIONS

High-quality materials and **careful machining**, for example, precise, **robot-welded welded seams**, are the basis for a long service life.

WORK COMFORTABLY

A perfectly designed workplace that offers everything, from the pleasant, **ergonomically designed seat** and the **responsive, precise control**, through to the clearly laid-out instruments and a large, **high-resolution colour display**.

TALL AND WIDE

Whether tall buildings or longer distances – the **ultra-long 28 m boom** offers an enormous range. The wide, **hydraulically telescopic chassis** and the **low centre of gravity** guarantee the required stability.

TOTALLY SAFE

No compromises when it comes to safety: The SY500HRD also impresses here down to the last detail – from the **standard camera** for visibility on all sides with no blind spots, through to the **safety valves**, from **hand rails** and **anti-slip tread surfaces**, through to the **protective grilles** for the driver's cab.

A FORCE FOR GOOD

The tried-and-tested, **large-volume six-cylinder- Isuzu engine** with 298 kW / 2 100 rpm is optimally equipped even for the most difficult demolition tasks.

IMPRESSIVE EFFICIENCY

The **intelligent control system** automatically adapts the pump power to the available engine power. This therefore only provides the oil quantity that is actually required for the hydraulics. The hydraulic pump therefore only works as much as is actually required. This results in outstandingly high efficiency **at the lowest possible engine speed**.

TECHNICAL HIGHLIGHTS

Engine	Isuzu6WG1X
Rated power	298 kW / 2 100 rpm
Max. torque	2 034 Nm / 1 400 rpm
Max. travel speed	1.4 km/h
Swingspeed	7 rpm
Mainpump	2 x variable-piston-pump with electronic positive control
Max. oilflow	2 x 360 l/min



„THE PURE POWER OF THE MACHINE IS IMPRESSIVE!“

Vasilis Ignators

Not all products are available in all markets. As part of our continuous improvement process, we reserve the right to modify specifications and designs without giving prior notice. The figures may contain additional options.

SANY

1800 837 888
vertuequipment.com.au
info@vertuequipment.com.au

Vertu Equipment
175 S Gippsland Hwy,
Dandenong
South VIC, 3175

