



# STRONG IN COMPACTION

AGILE. COMPACT. ROBUST.

CONSTRUCTION MACHINERY



**TANDEM ROLLERS**  
**STR30C-8**  
**STR50C-8**

Motor  
Yanmar 3TNV88 / Kubota  
Power  
**28.1kW / 36kW**  
Drum Width  
**1200 mm / 1380 mm**  
Operating Weight  
**3000kg / 4500kg**



# SANY

## For challenging tasks, you need a first-class partner

First-class quality comes from experience - it's no wonder that this is one of SANY's most important success factors. Today, we are one of the leading roller manufacturers, producing over **50,000** rollers a year. This means that you benefit from well engineered products with an impressive track record – products that you can rely on. An impressive **5–7%** of our annual turnover is dedicated to research and development. This is why we give you not only our word, but also our extraordinary **five-year warranty** as a guarantee of how powerful and robust our products are.

**50 000**  
ROLLERS SOLD  
**WORLDWIDE**

**5–7%**  
REVENUE FOR RESEARCH  
AND DEVELOPMENT



**STR30C-8 | STR50C-8**

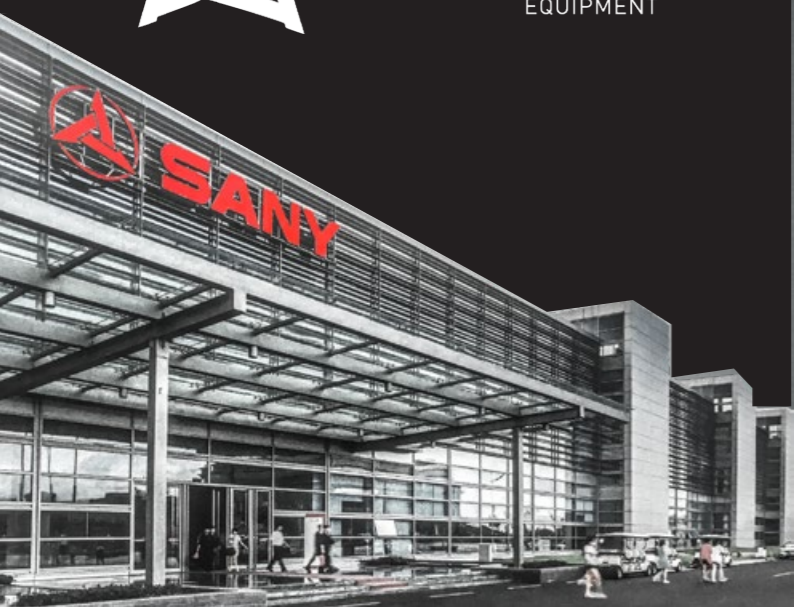

### STR30C-8 | STR50C-8 HARD FACTS

Transport height  
2 585 mm  
2 700 mm  
Overall length  
2 544 mm  
2 900 mm  
Max. speed  
10 km/h  
12 km/h

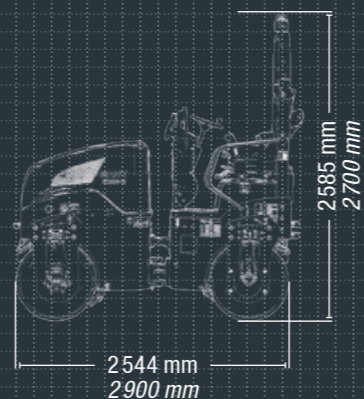

## LIGHTWEIGHT TANDEM ROLLERS, WHICH HAVE WHAT IT TAKES

The tandem rollers in the under 5 t series are ideal for construction and maintenance work on medium and small construction projects. They impress wherever soil, gravel or asphalt compaction requires precision and productivity. Their impressive performance is based on a high level of driving and operating comfort as well as excellent visibility. This makes them particularly efficient for compaction work on cramped construction sites or along side boundaries such as house walls. In addition, our rollers are extremely robust and reliable – the foundation for the great feeling of a safe investment.



**QUALITY**

**Robust and durable** – All essential protective elements, reinforcements, steps and tanks are made of high-quality metal. So quality becomes the best protection for your investment. Ideal for demanding applications on construction sites.

**RATED POWER**

**High compaction efficiency** – The STR30C-10 and STR50C-10 impress with their linear load and amplitude. Adjustable frequencies enable optimum compaction results to be achieved with every task.

**USER EXPERIENCE**

**Extremely comfortable** – From easy access to the laterally adjustable comfortable seat and the ergonomically designed controls, drivers can look forward to maximum driving comfort.

USER EXPERIENCE

**UNCOMPLICATED IS THE KEY**

The driving platform is designed for comfortable and safe operation. All important information and functions can be called up intuitively via the touch-screen display. The multifunction control levers respond directly to the operator's commands, allowing relaxed and safe working.

The decoupling of the frame from the machine ensures fatigue-free, focused work and the eco-stop function automatically switches off the machine when not in use.

As operator comfort is synonymous with productivity, the SANY tandem rollers lead the way here, too: the seat and armrest are individually adjustable, and the driver's seat, including the second control lever, can be moved sideways.



**COMPONENTS**

**Good as standard** – SANY tandem rollers rely on proven quality. That includes high-quality core components from renowned brand manufacturers, such as drive pumps by Danfoss together with Kubota / Yanmar engines. They guarantee high performance, even when working on inclines.

**ECONOMY**

**Economically convincing** – When it comes to costs, SANY tandem rollers are the first choice: favourable purchase price, long maintenance intervals and economical consumption in compliance with stage V emissions standards.

**SAFETY**

**No ifs and buts** – Enables safe and precise work even in cramped spaces. The STR30C-8 and STR50C-8 are equipped with a folding ROPS, rotating beacon and road lighting.

SAFETY

**Protection down to the tiniest detail**

If the worst comes to the worst, the ROPS protects the driver – but the rollover protection can be folded down quickly and easily for transport or when working in confined spaces. The seat contact switch reliably recognises whether the operator is sitting in the seat. This protects against unintentional movements of the machine.

The articulated joint lock for loading, unloading and transport, sturdy galvanised lashing eyes, emergency stop switch, battery master switch, reversing alarm and rotating warning light complete the safety equipment.





QUALITY

# UNCOMPLICATED MAINTENANCE IS KEY

Regular inspection and maintenance work ensures a good performance and service life of the machine. We therefore make these tasks as easy as possible for the operator. The robust articulated joint is completely maintenance-free, and all maintenance-relevant components are easily accessible thanks to the high opening angle of the engine bonnet.



COMPONENTS

# CONVINCING PERFORMANCE

Powerful compaction technology meets reliable quality. The tandem rollers from SANY ensure both of these things thanks to high-quality components from brand manufacturers. This includes reliable hydraulic pumps from Danfoss and Poclain hydraulic motors for good traction and reliability.



## Our highlights – the added benefits SANY offers you:

- + Precise operation thanks to the multifunction control lever
- + Seat together with second control lever can be moved sideways
- + Adjustable amplitude frequencies
- + User-friendly touch display
- + Extensive safety equipment



ECONOMY

## Combining performance and efficiency

It's not only users on construction sites who love the STR30C-10 and STR50C-10 from SANY. The accounts department are also happy, as the tandem rollers of the sub-5-tonne series keep costs down.

Low purchase costs, low maintenance requirements and reduced expenses for ongoing operation guarantee maximum operating time at low overall costs.



RATED POWER

## Effective compaction

The SANY tandem rollers are packed with power. The Kubota / Yanmar engines provide sufficient power to perform even extensive projects cost-effectively.

The high linear load and large amplitude ensure fast and even compaction – and therefore efficient processing of larger areas.





ENGINE	30C-8	50C-8
Model	Yanmar 3TNV88	Kubota D2607
Type	Water-cooled 3-cylinder diesel Engine with common-rail injection system and turbocharger	Water-cooled 4-cylinder diesel Engine with common-rail injection system and turbocharger
Rated power	28.1kW/2 400 rpm	36 kW/2 000 rpm
Emission standard	Tier 4	Tier 4
Fuel	Diesel	Diesel

STEERING	30C-8	50C-8
Type of steering	Articulated	Articulated
Steering method	Hydrostatic	Hydrostatic
Steering angle, angle of oscillation +/-	32°/10°	32°/8°
Crab steering	50 mm	50 mm

DRUM	30C-8	50C-8
Number of drums	2	2
Front drum type	Smooth, undivided	Smooth, undivided
Rear drum type	Smooth, undivided	Smooth, undivided
Front drum width	1 200 mm	1 380 mm
Rear drum width	1 200 mm	1 380 mm
Front drum diameter	700 mm	900 mm
Rear drum diameter	700 mm	900 mm
Drum shell thickness	14 mm	18 mm

DRIVING CHARACTERISTICS	30C-8	50C-8
Speed	10 km/h	10 km/h
Working speed with vibration	10 km/h	12 km/h
Max. gradeability without vibration	40 %	40 %
Max. gradeability with vibration	30 %	30 %

WEIGHTS	30C-8	50C-8
Operating mass CECE	3000 kg	4500 kg
Front axle load CECE	1 500 kg	2 250 kg
Rear axle load CECE	1 620 kg	2 250 kg
Front static line load CECE	12.25 kg/cm <sup>2</sup>	16.3 kg/cm <sup>2</sup>
Static linear load, rear CECE	13.5 kg/cm <sup>2</sup>	16.3 kg/cm <sup>2</sup>
French classification, value/class	V0	V0

SCRAPER	30C-8	50C-8
Scraper material	PVC	PVC
Scraper type	Folding / spring-loaded	Folding / spring-loaded

SPRINKLING	30C-8	50C-8
Sprinkling type	Pressure sprinkling	Pressure sprinkling

GROUND DRIVE	30C-8	50C-8
Drum drive	Radial piston motor	Radial piston motor
Service brake	Hydrostatic	Hydrostatic
Parking brake	Spring-loaded claw brake	Spring-loaded claw brake

EXCITER SYSTEM	30C-8	50C-8
Frequency (1)	55 Hz	50 Hz
Frequency (2)	67 Hz	60 Hz
Amplitude (1)	0.5 mm	0.5 mm
Amplitude (2)	0.5 mm	0.5 mm
Centrifugal force (1)	28 kN	47 kN
Centrifugal force (2)	46 kN	68 kN
Exciter type	Circular exciter	Circular exciter

SERVICE CAPACITIES	30C-8	50C-8
Fuel tank	60 l	68 l
Water	230 l	310 l
Hydraulic oil	50 l	40 l

HYDRAULIC SYSTEM	30C-8	50C-8
Drive pump	Axial piston pump	Axial piston pump
Drive pump manufacturer	Danfoss	Danfoss
Traction motor	Radial piston motor	Radial piston motor
Traction drive manufacturer	Poclair	Poclair
Vibration pump	Gear pump	Gear pump
Vibration motor	Gear motor	Gear motor
Steering pump	Danfoss	Danfoss

DIMENSIONS	30C-8	50C-8
A Transport length (transport position)	2544 mm	2900 mm
B Transport width	1312 mm	1484 mm
C Transport height	2585 mm	2700 mm
D Transport height	1960 mm	2085 mm
E Wheelbase	1700 mm	2000 mm
F Inner turning circle	2650 mm	2797 mm
G Ground clearance	245 mm	350 mm
H Working width	1200 mm	1380 mm
I Max. working width	1250 mm	1430 mm

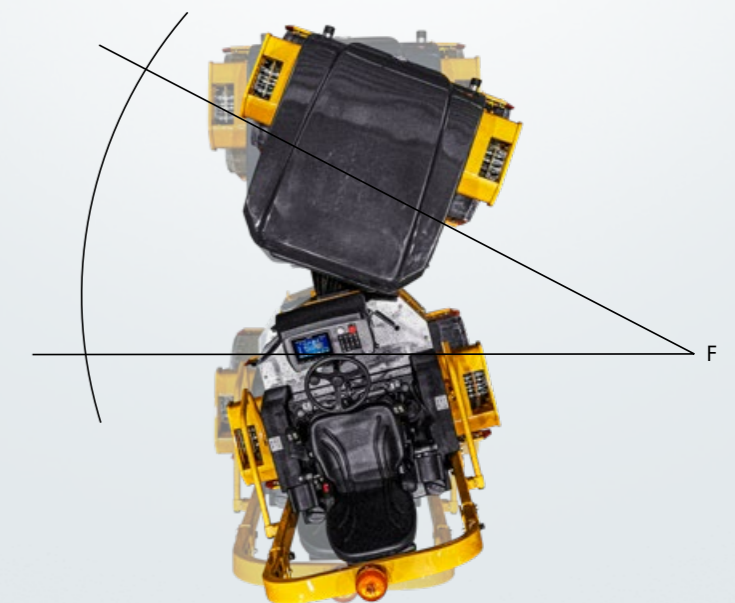



STR30C-8 | STR50C-8



Many extras already included ex works

The SANY tandem rollers STR30C-8 and STR50C-8 are already equipped with many extras as standard. Vandalism protection, 12 V socket and USB charging socket are already on board ex works.

8

OPERATING COMFORT/CAB 30C-8 50C-8

Multifunction control lever	●	●
Multifunction display	●	●
Seat with adjustable armrest	●	●
Driver's seat can be moved with both control levers	●	●
Vandalism protection	●	●
12V socket	●	●
USB charging socket	●	●

SAFETY 30C-8 50C-8

Direction indicator and hazard warning lights	●	●
Battery disconnection switch	●	●
Seat contact switch	●	●
ROPS including seat-belt	●	●
Reversing alarm	●	●
Beacon lamp	●	●
Emergency stop switch	●	●
Lockable hood	●	●
Articulated joint lock	●	●
Lockable fuel tank cover	●	●
Operating instructions in local language	●	●
Rotating beacon	●	●

LIGHTS 30C-8 50C-8

Lights for road travel	●	●
Working lights (front)	●	●
Working lights (rear)	●	●

WORKING EQUIPMENT 30C-8 50C-8

Scraper	●	●
Galvanised lashing eyes	●	●

Standard equipment ● Special option ●

The standard and special options differ depending on the country in which the crawler excavator is delivered. If you have any questions, please contact your dealer directly.

# A SERVICE YOU CAN RELY ON



In the event of a breakdown during your warranty period, Vertu will come to your site as soon as possible to get your machine back up and running. If the repair cannot be undertaken on-site or in good time, Vertu will arrange a similar replacement while your machine is repaired under warranty.

National Service Representation

Our national service network partnerships provide certainty that you are supported with service and parts, wherever you are located.

Parts and Inventory

As the dealer of SANY excavators, roading and construction equipment Vertu holds a significant inventory of SANY Genuine and aftermarket parts and attachments, both in New Zealand and Australia to keep you going. With direct relationships locally and internationally we can source parts quickly and as a matter of priority.

Flexible, Fast and Always there for you

Paid assistance, tailored advice and a reliable supply of original parts all around New Zealand. That is what we mean by premium service.

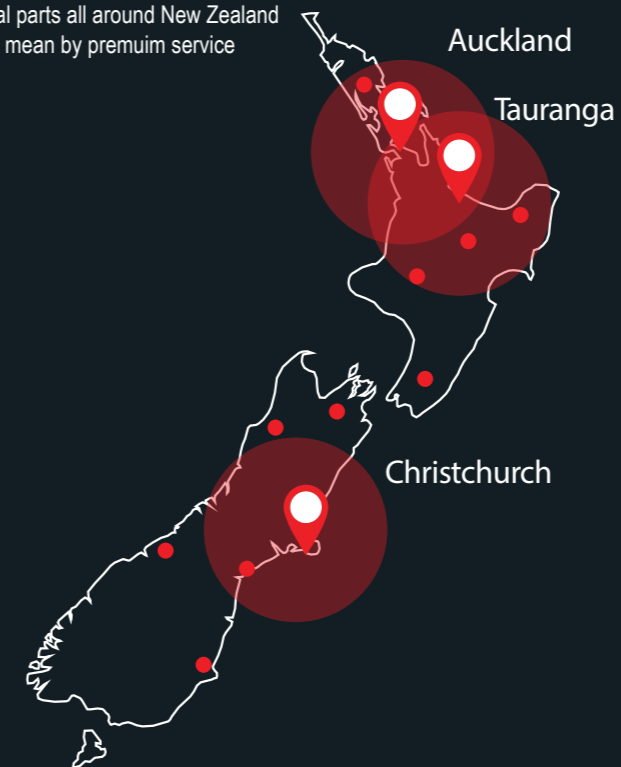

The added benefits SANY offers you:

- Fast supply thanks to the New Zealand Vertu Locations
- More than 15,000 spare parts to make your machine highly reliable
- Expert knowledge for optimal supply for your machine
- Thanks to SANY's special training programme, our dealers are always kept up-to-date so that they can face all technical challenges.

Parts supply – quick and reliable

With the purchase of a SANY tandem roller you have made an investment in the future. Fast availability of spare parts is your guarantee of minimal downtimes and failure times.



Detailed information in black and white

Handbooks and documents are available for all SANY crawler excavators, and these can help you with operation, maintenance, servicing and repairs. These include operating and maintenance instructions and technical specifications.



# TANDEM ROLLERS THAT MAKE THE RIGHT IMPRESSION

The lightweight SANY tandem rollers impress with their versatility and cost efficiency. They demonstrate their strengths in gardening and landscaping, asphalt construction, repair work and follow-up work. Articulated steering offers excellent manoeuvrability for precise work, especially where space is tight and maximum precision is required. This makes compaction work even more economical and productive. The robust workmanship and uncomplicated operation make them ideal for use in tough everyday construction site conditions.



## ROBUST AND DURABLE

Tandem rollers have to withstand a lot in tough everyday construction site conditions. No problem for SANY machines. **High-quality materials and precision in manufacturing** safeguard your investment in the long term.

## HIGH COMPACTION EFFICIENCY

Whether dealing with cohesive or non-cohesive soils, base and anti-frost layers or asphalt - with a SANY STR30C-10 or STR50C-10 you are optimally equipped **for all soil types and all compaction projects**.

## EXTREMELY COMFORTABLE

The comfort of the operator is a **decisive factor for the productivity** of the machine. This is another reason why the driver's cabs of SANY tandem rollers are uncompromisingly designed for comfort.

## NO IFS OR BUTS

From seat contact switches, emergency stop and battery master switches to rotating warning lights, road lighting and reversing alarms, everything is on board to ensure the **safety of man and machine** on the construction site.

## GOOD AS STANDARD

High-quality core components from renowned brand manufacturers are the foundation for high efficiency. The **powerful Kubota/Yanmar engines** for example, allow a rapid working pace even on inclines.

## ECONOMICALLY CONVINCING

Low operating costs are standard for all SANY tandem rollers. An **economical drive unit and long maintenance intervals** are a distinct competitive advantage.

## TECHNICAL HIGHLIGHTS STR30C-10

Engine	Yanmar 3TNV88
Drum diameter front/rear	700 mm / 700 mm
Working speed with vibration	10 km/h
Steering angle, angle of oscillation +/-	32° / 10°
Drive pump	Axial piston pump

## TECHNICAL HIGHLIGHTS STR50C-10

Engine	Kubota V2607
Drum diameter front/rear	900 mm / 900 mm
Working speed with vibration	12 km/h
Steering angle, angle of oscillation +/-	32° / 8°
Drive pump	Axial piston pump

Not all products are available in all markets. As part of our continuous improvement process, we reserve the right to modify specifications and designs without giving prior notice. The figures may contain additional options.

**SANY**

Vertu Equipment  
0800 837 888  
www.vertuequipment.co.nz  
info@vertuequipment.co.nz

Auckland  
510 Ellerslie-Panmure Hwy  
Mount Wellington

Tauranga  
67 Hull Road,  
Mount Maunganui

Christchurch  
52 Hickory Place,  
Islington

